

# **Application Note**



**Disk based passive samplers for the analysis of 22  
chlorinated acid herbicides in water surfaces using  
**AttractSPE® Disks Anion Exchange - SR****

Chlorinated acid herbicides are a family of molecules widely used in agriculture. These contaminants are likely to be found in water surfaces (rivers, lakes,...) and some of them like 2,4-D have proven harmful effects on health. Passive sampling allows the surveillance of contaminants in water surfaces over a short period (less than 7 days) or longer (1 month), in which no energy, maintenance or control is necessary. An average of the concentration of contaminants is then determined in laboratory. This application note describes an in-vitro experiment over a period of 9 days for the passive sampling of 22 chlorinated acid herbicides (Table 1) in water using **AttractSPE® Disks – Anion Exchange – SR** as Disks based passive samplers. **Attract®SPE Disks** are thin, dense, soft and uniform extraction SPE membranes with a high surface area of exchange that allows the best interactions with analytes to obtain excellent recoveries. **AttractSPE® Disks**, used as passive samplers, makes extraction and processing easier after the sampling step. Several formats and chemistries are available to best suit each application.

**Table 1.** List of the 22 tested chlorinated acid herbicides

Compound	CAS Number	Compounds	CAS Number
Aminopyralid	150114-71-9	3,5 dichlorobenzoic acid	51-36-5
Clopyralid	1702-17-6	Dichlorprop	120-36-5
Picloram	1918-02-1	2,4,5-T	93-76-5
Dicamba	1918-00-9	Mecoprop (MCP)	93-65-2
4-nitrophenol	100-02-7	Dalapon	75-99-0
Fluroxypyr	69377-81-7	loxynil	1689-83-4
Bentazone	25057-89-0	2,4-DB	94-82-6
2,4-D	94-75-7	Fenoprop	93-72-1
MCPA	94-74-6	Acifluorfen	50594-66-6
Bromoxynil	1689-84-5	Dinoseb	88-85-7
Triclopyr	55335-06-3	Pentachlorophenol	87-86-5

# 1 Description and conditioning of the disk based passive sampler

A 47mm **AttractSPE® Disks - Anion Exchange – SR** (SAX) and a diffusion membrane are trapped between two stainless steel disks (figure 1). A 40mm diameter opening is present on the front steel disk to allow exchanges between the environment and the SPE disk.

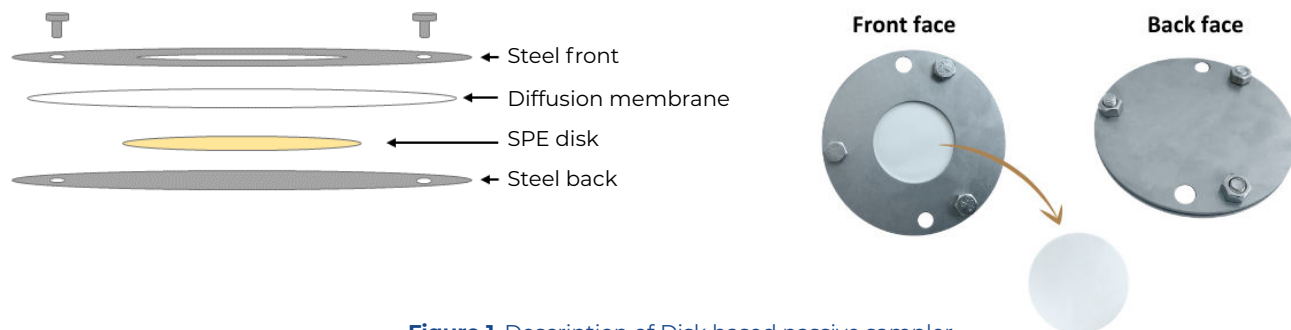

Figure 1. Description of Disk based passive sampler

A diffusion membrane overlaid on the SPE disk lengthen the equilibrium reach, protect the integrity of the disk, and therefore allows an extended time of deployment (Townsend et al. [1]).

- The diffusion membranes are preconditionned and dried before use.
- For each SPE disk: Place the SPE disk on the disk manifold and condition with Acetone (soak 30 seconds), Methanol (soak 30 seconds), 50 mL ultrapure water, 50 mL NaOH 1M in water, 50 mL ultrapure water. Do not let the disk go dry.
- The disk based passive sampler is then assembled and kept in ultrapure water until field deployment

# 2 Description of the assembly (figure 2)

The experiment was processed in a fish tank made of glass (40x40x40cm). 50 liters of mineral water spiked at 1µg/L with the analytes was at first put into the tank. MCPA and MCPP are at a concentration of 100µg/L due to the mix used. For the entire duration of the experiment, water from the tank was constantly drained out and replaced with unspiked mineral water using a peristaltic pump at the speed of around 17 Liters per day.

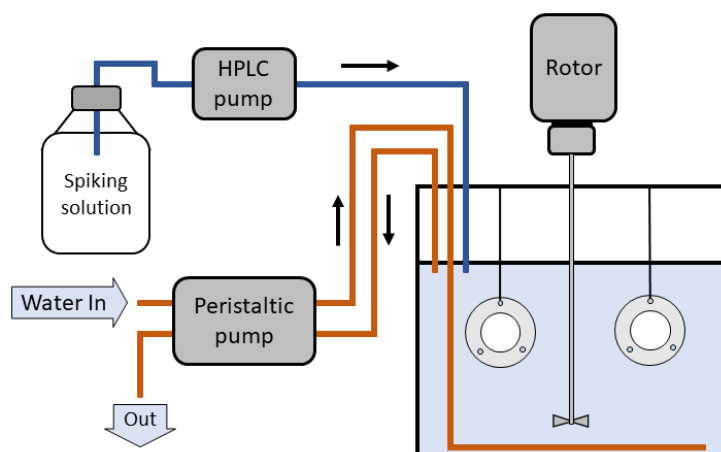

Figure 2. Assembly diagram

A spiking solution (22 chlorinated acid herbicides in ultrapure water) was injected directly into the tank using HPLC pump. The flowrate of the spiking solution was around 0.2mL/min (288mL/day) and the concentration of the solution was calculated so that the concentration of the analytes in the tank remains constant and at approximately 1µg/L (100µg/L for MCPA and MCPP). The spiking solution was kept in an amber glass bottle at ambient temperature and constantly agitated using a magnetic stirrer at moderate speed. The water in the tank was kept agitated using a rod with propeller attached to a drill at a speed of 45 RPM to simulate a flow. The temperature during the experiment was between 19.6°C and 22.1°C and thus considered constant.

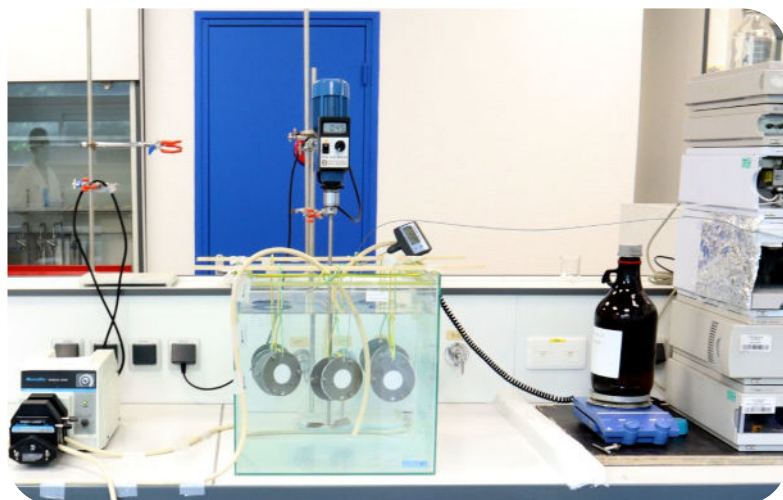

Figure 3. Picture of the experimental setup

### 3 Proceeding of the experiment

The sampling capacity of the disk based passive samplers was tested from 1 to 9 days with two passive samplers for each day (identified as a set), for a total of 18 passive samplers. At any moment 10 samplers were simultaneously immersed in the tank following the immersion schedule (Figure 4). For example, after 1 day, the “1 day set” was removed from the tank and replaced by the “8 days set”. After the removal of a set, the passive samplers were rinsed with ultrapure water and stored in the fridge in an aluminum sachet until the extraction procedure.

	Day									
	0	1	2	3	4	5	6	7	8	9
1 day set	Blue	White	White	White	White	White	White	White	White	White
2 days set	Blue	Blue	White	White	White	White	White	White	White	White
3 days set	Blue	Blue	Blue	White	White	White	White	White	White	White
4 days set	Blue	Blue	Blue	Blue	White	White	White	White	White	White
5 days set	White	White	White	White	Blue	Blue	Blue	Blue	Blue	Blue
6 days set	White	White	White	Blue	Blue	Blue	Blue	Blue	Blue	Blue
7 days set	White	White	Blue	Blue	Blue	Blue	Blue	Blue	Blue	Blue
8 days set	White	Blue	Blue	Blue	Blue	Blue	Blue	Blue	Blue	Blue
9 days set	Blue	Blue	Blue	Blue	Blue	Blue	Blue	Blue	Blue	Blue

Figure 4. Immersion schedule (Blue = Immersed; White = Not immersed)

### PROTOCOL FOR TREATMENT OF ATTRACTSPE® DISKS - ANION EXCHANGE – SR

1. Take the passive sampler out of the water and rinse it with ultrapure water
2. Dismantle the passive sampler
3. Dismantle the diffusion membrane
4. Place the SPE disk onto the manifold and apply the following protocol

#### Washing

1. 20mL ultrapure water
2. Dry disk 1 minute under full vacuum

#### Elution

20 mL 3% formic acid in acetonitrile (soak disk for 30 seconds prior to elution, then elute in about 20 seconds)

#### Analysis

The eluate was then agitated and diluted (1:4 ratio) with ultrapure water prior to analysis.



SPE disk manifold for AttractSPE® Disks

After the extraction procedure, the concentration of the molecules in each passive sampler were simultaneously analyzed by LC-MS/MS (Table 2).

**Table 2.** LC-MS/MS conditions of analysis

LC Conditions	MS/MS Conditions
LC Dionex U3000	Qtrap 4000 ESI+ MS/MS
Column : SiliactHPLC LC.A 150*2.1mm at 40°C	Curtain gas : 30
	CAD : High
Injection volume : 20µL	IS : 4500V
T° sampler : 10°C	Temperature : 400°C
Flow rate : 0.2mL/min	GS1/GS2 : 30/30

Analyte	Retention time (min)	Q1 (m/z)	Q3 (m/z)	CE (V)
Aminopyralid	3.6	205.0	160.9	-12
Clopyralid	5.1	190.0	145.7	-14
Picloram	7.1	238.9	194.8	-14
Dicamba	10.3	219.0	174.9	-10
4-nitrophenol	11.1	138.0	108.0	-24
Fluroxypyr	11.5	253.0	195.0	-16
Bentazone	12.3	239.0	131.8	-36
2,4-D	12.9	247.0	161.0	-12
MCPA*	13.1	199.0	35.1	-50
Bromoxynil	13.5	275.9	78.8	-48
Triclopyr	13.6	255.9	197.8	-16
3,5 dichlorobenzoic acid	13.8	189.0	144.9	-16
Dichlorprop	14.0	233.0	160.8	-20
2,4,5-T	14.0	252.9	194.8	-18
Mecoprop (MCP)*	14.1	213.1	70.8	-30
Dalapon	14.1	141.0	35.1	-36
Ioxynil	14.4	369.9	127.0	-50
2,4-DB	14.7	247.0	161.0	-12
Fenoprop	15.0	266.9	194.7	-16
Acifluorfen	15.1	360.0	315.9	-14
Dinoseb	17.1	239.0	192.8	-34
Pentachlorophenol	17.3	264.8	35.0	-48

\*For MCPA and MCP, the most intense transition was not chosen to avoid saturation of the signal because of higher concentration.

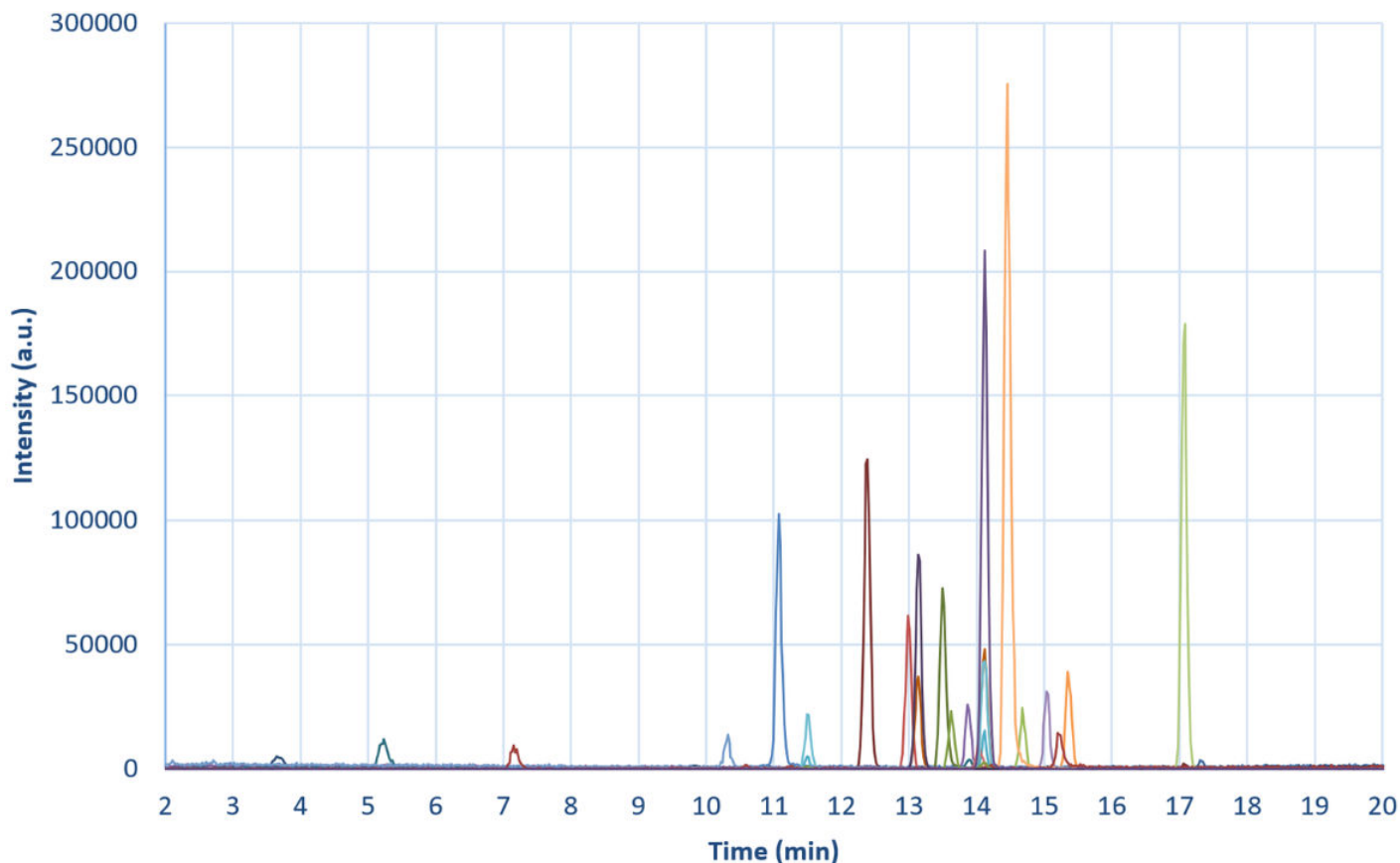

Figure 5.. LC-MS/MS chromatogram of chlorinated acid herbicides at 2 µg/L.

## 5 Results

The curve of the adsorbed mass on the disk in function of the sampling duration was drawn for each molecule (see figure 6 and figure 7). The uptake was observed as linear over the 9 days of the experiment for the 22 molecules.

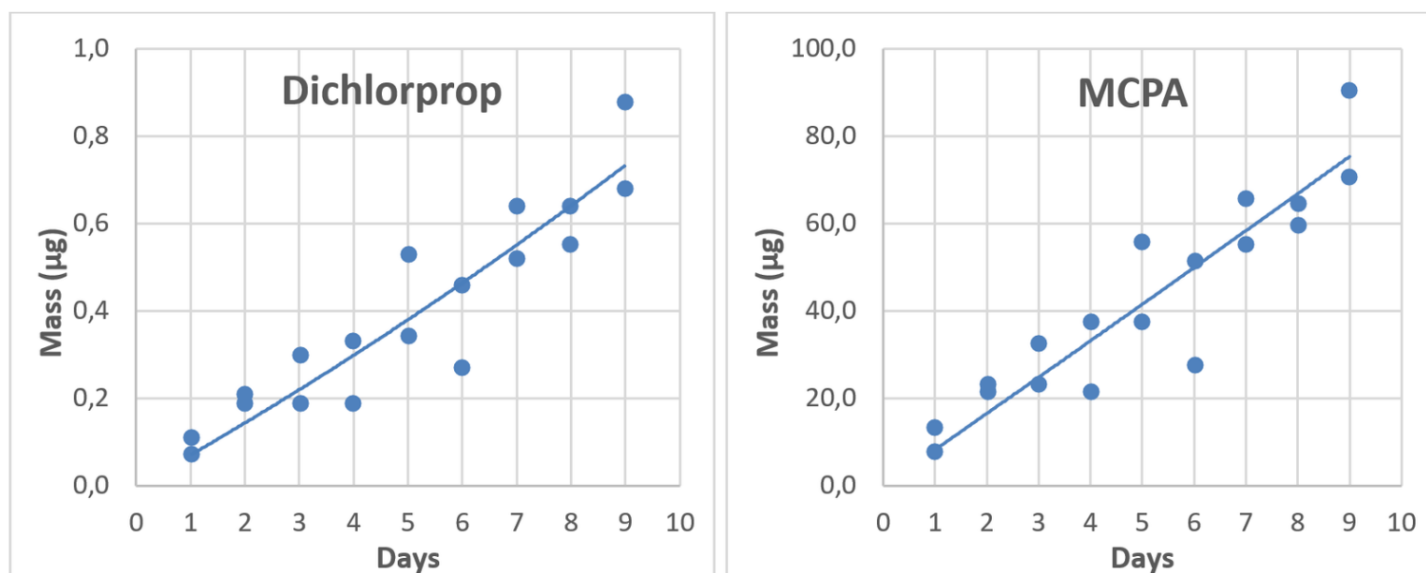

Figure 6. Uptake curve for Dichlorprop and MCPA measured during the experiment. See at the end of the application note for the other curves.

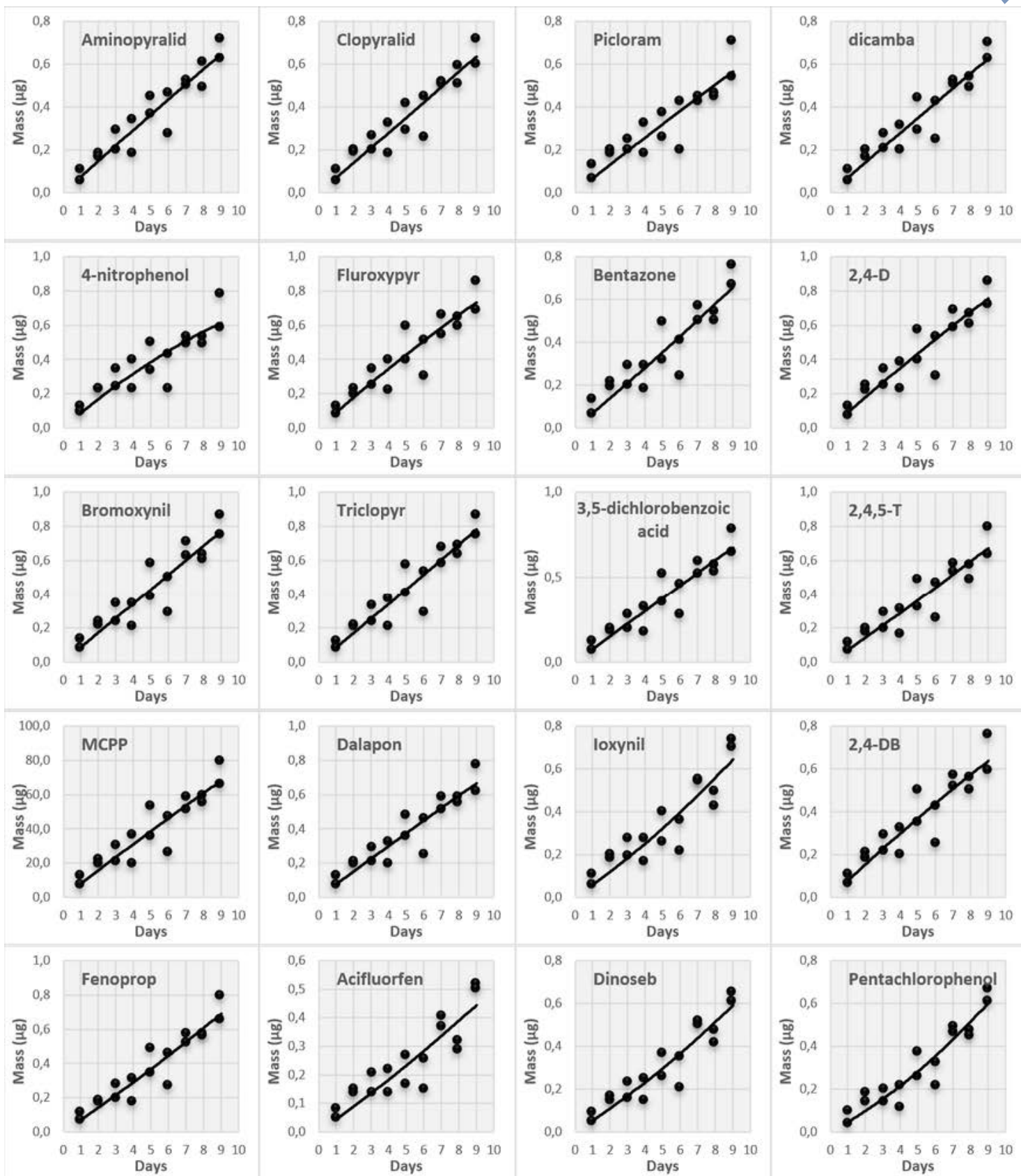

Figure 7. Uptake curve for the 20 remaining molecules measured during the experiment.

The sampling Rate was calculated for each molecule using the formula below.

$$Rs \text{ (L/days)} = \frac{C_{\text{sampler}} \text{ (}\mu\text{g/g)} \times M_{\text{sampler}} \text{ (g)}}{C_{\text{tank}} \text{ (}\mu\text{g/L)} \times \text{time (days)}}$$

The values from day 2 to day 7 were considered for a total of 12 values leading to a mean calculated Rs and a standard deviation value. The results obtained are presented in Table 3.

**Table 3.** Sampling rates and standard deviation obtained for the 22 chlorinated acid herbicides in mineral water using **AttractSPE® Disks – Anion Exchange – SR** as passive samplers.

Analyte	Retention time (min)	Q1 (m/z)
Aminopyralid	0.069	0.018
Clopyralid	0.073	0.018
Picloram	0.068	0.019
Dicamba	0.073	0.017
4-nitrophenol	0.083	0.024
Fluroxypyr	0.084	0.021
Bentazone	0.071	0.021
2,4-D	0.087	0.022
MCPA	0.083	0.022
Bromoxynil	0.085	0.022
Triclopyr	0.085	0.020
3,5 dichlorobenzoic acid	0.074	0.018
Dichlorprop	0.077	0.020
2,4,5-T	0.073	0.018
Mecoprop (MCP)	0.077	0.020
Dalapon	0.074	0.020
Ioxynil	0.070	0.018
2,4-DB	0.074	0.019
Fenoprop	0.071	0.017
Acifluorfen	0.052	0.014
Dinoseb	0.060	0.015
Pentachlorophenol	0.053	0.016

# CONCLUSION

**AttractSPE® Disks Passive Sampler** using **AttractSPE® Disks– Anion Exchange - SR** was used to collect 22 chlorinated acid herbicides. Rs values were measured between 0.052 to 0.087 L/day with a good linearity over the 9 days. The results found are consistent with those of Townsend et al. [1]. The MCPA and MCPP (100 times more concentrated) also showed a good linearity, demonstrating the high capacity of the SPE disk.

## Acknowledgments:



We would like to express our sincere thanks to the Normandy region for the funding they granted us which made this project possible. We also would like to express our thanks to Ms. Julphie MPONDO (Analytical chemist) who was responsible for carrying out this study. Her seriousness and involvement made it possible to carry out this study successfully.

## References

1. Townsend et Al. (2018) Calibration and application of the chemcatcher® Passive sampler for monitoring acidic herbicides in the river Exe, UK catchment. *Environ Sci Pollut Res* 25:25130-25142

## Product references:



### AttractSPE® Disks Passive Sampler Anion Exchange – SR

Quantity: 10/pk

**DBPS.AN.90.40.kit.10**



### SPE Disks manifold 47mm – 1 station

Quantity: 1 unit

**ACC-DISKSPE-G47-1**

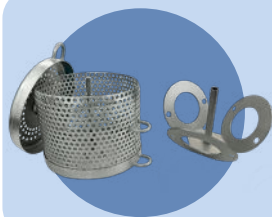

### 1 Canister 12 cm + 1 holder 3 position

Quantity: 1 unit

**CH-3P.A.1**



### SPE Disks manifold 47mm – 3 station

Quantity: 1 unit

**ACC-DISKSPE-G47-3**

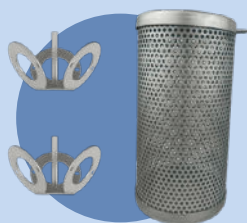

### 1 Canister 24cm + 2 holders 3 position

Quantity: 1 unit

**CH-6P.A.1**



### SPE Disks manifold 47mm – 6 station

Quantity: 1 unit

**ACC-DISKSPE-G47-6**

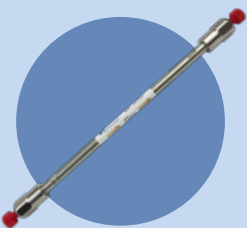

### SilactHPLC LC.A, 150 x 2.1mm, 3µm

Quantity: 1 unit

**LC.A-150.2.1**